

GLOBBER

globber.com



E-MOTION 27

350W

FOLDABLE ELECTRIC SCOOTER/
TROTINETTE ÉLECTRIQUE PLIABLE



Original instructions
Instructions d'origine

Class 2 / Classe 2

EN17128:2020

Personal Light Electric Vehicle (PLEV)

14+

100 kg
220lbs
max

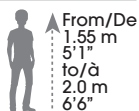

Please keep these instructions for future reference.
 EN 17128:2020 CLASS 2: 100KG MAX
 READ THE INSTRUCTIONS PROVIDED BY THE MANUFACTURER BEFORE USING
 THE PRODUCT.



1 - SAFE USE OF THE ELECTRIC SCOOTER

This appliance can be used by children aged from 14 years old and above and by persons with reduced physical, sensory, or mental capabilities or those with lack of experience and knowledge, if they have been given supervision or instruction concerning use of the appliance in a safe way and understand the hazards involved. Young children shall not play with the appliance. Cleaning and user maintenance shall not be done by children without supervision.

Warning: Never use the product close to a water source. Stop using the product if damaged.

Warning: Never use the product outside of the spaces authorized by the local laws and regulations.

DETACHABLE SUPPLY UNIT

WARNING: For the purposes of recharging the battery, use only the detachable supply unit provided with this appliance. This appliance contains batteries that are only replaceable by skilled persons. Persons with reduced physical, sensory, or mental capabilities or lack of experience and knowledge shall not play with nor recharge the battery.

2 - TECHNICAL SPECIFICATION

Material	Composite, aluminium, polypropylene, TPR, rubber, silicone
Assembled dimension	L109cm x W47cm x H112cm
Folded Dimension	L110cm x W47cm x H46.5cm
Weight	13 kg
User height /maximum weight	1.55-2.0 m / 100 kg
Maximum speed	Speed mode 1: 6 km/h (3.7 mph) Speed mode 2: 18 km/h (11.2 mph) Speed mode 3: 25 km/h (15.6 mph)
Maximum range per charge	25-28 km*
Operating temperature	0°C - 40°C
Motor power	350W
Front wheel size	8.5" (220 mm) (inflatable wheel)
Rear wheel size	8.5" (220 mm) (honey comb rubber wheel)
Battery capacity (Ah)	7.8Ah
Battery voltage	36V (End-of-discharge voltage: 27.5V - Upper limit of the charging voltage: 42V)
Charger model no: CP4215	AC input: 100-240V - 50/60Hz - 3A DC output: 42V  1.5A
Charging time	5-6 hours
Sealing around compartment	IPX4

*Depending on the user's weight.
 Original instructions

3 - CONTROL FUNCTIONS

SCREEN FUNCTIONS

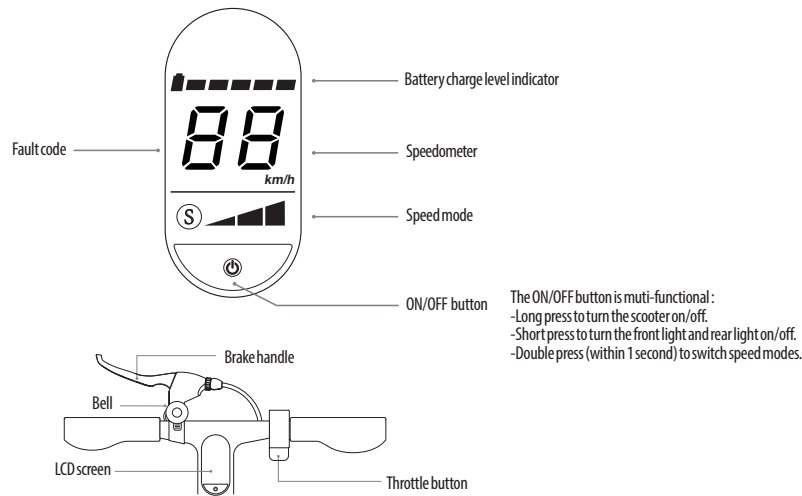

ON/OFF FUNCTION

- To start the scooter, press and hold the ON/OFF button located at the bottom of the LCD screen. Always remember to press the ON/OFF button to start the scooter.
- When the LCD screen lights up, the scooter is in "ON" mode.
- To turn off the scooter, press and hold the ON/OFF button until the LCD screen turns off.
- Your E-MOTION 27 will automatically turn off after 10 minutes of inactivity.

START-UP

Once the scooter is in ON mode, it is now ready to use. Two actions are necessary to engage the motor:

- Press the throttle accelerator (located on the right handlebar) to start and accelerate. Kick start to activate the motor.
- Push your scooter to reach a speed of 3 km/h.
- Be aware that once the motor is turned ON, reducing your speed below 3 km/h does not automatically turn off the motor; read the "STOP" paragraph section for instructions on how to turn off the motor.

HOW TO RIDE THE SCOOTER

- Make sure the scooter is in "ON" mode.
- Place your feet on the deck.
- Push the scooter with your foot until you reach a speed of 3 km/h to engage the electric motor.
- Press the throttle accelerator (located on the right handlebar) to start and accelerate.
- The maximum speed is 25km/h in speed mode 3, 18km/h in speed mode 2, and 6km/h in speed mode 1.
- To slow down, you can simultaneously or independently:
 - Carefully press the handbrake while keeping both hands on the handlebar.
 - Release the throttle accelerator while keeping both hands on the handlebar.







STOP

- To stop, press the brake lever on the left side of the handlebar to engage the rear wheel brake. The action of the brake lever will simultaneously engage the electromagnetic motor brake and the mechanical brake of the rear wheel.
- At any time, you can remove your finger from the acceleration throttle to automatically shut down the motor, for example in an emergency. The battery will automatically turn itself off when the motor is not engaged for more than 10 minutes.

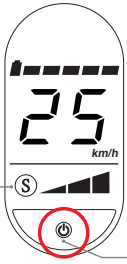
SPEED MODE SELECTION

When you first press the ON/OFF button, the scooter is by default in "speed mode 3". When the scooter is in "ON" mode, but the motor is not engaged, the scooter is in "standby mode".

In standby mode, you can switch between the 3 speed modes by double-clicking the ON/OFF button.

 <p>Speed mode symbol</p> <p>Double press to change the speed modes</p>	<p>Speed mode 3 (default mode): Max speed is 25km/h. The LCD screen will show 3 bars on the « S » speed symbol. </p>
	<p>Speed mode 2: Max speed is 18km/h. The LCD screen will show 2 bars on the « S » speed symbol. </p>
	<p>Speed mode 1 (pedestrian mode): Max speed is 6km/h. The taillight will flash. The LCD screen will show 1 bar on the « S » speed symbol. </p>

Remember, to switch from "speed mode 3" to "speed mode 2", double-click the ON/OFF button. Then, to switch from "speed mode 2" to "speed mode 1" double-click again the ON/OFF button. Finally, to switch back back from « speed mode 1 » to « speed mode 3 » double click again the ON/OFF button.

FRONT LIGHT

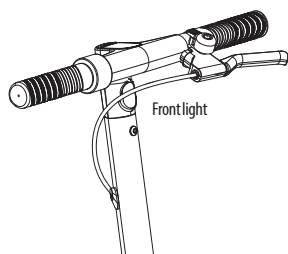

- Short press the ON/OFF button to turn on the front light. The taillight will light up.
- To turn off the front light and taillight, short press the ON/OFF button again.

4 - ASSEMBLY UNFOLD THE SCOOTER

Step 1. Open the lever and raise the t-bar to the maximum height until the folding mechanism is locked.

Note: Please ensure that the folding lever is open before you raise the t-bar. Otherwise, the t-bar cannot lock in the upright position.

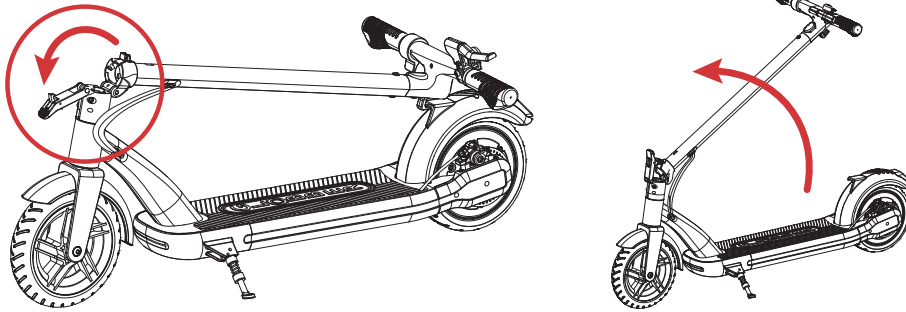

Step 2. Close the folding lever completely and ensure that the red button is clipped into the square hole.

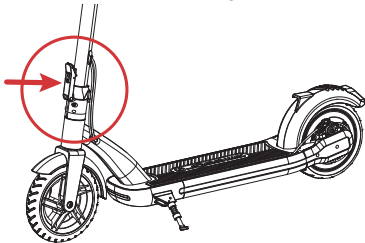

HANDLE BAR ASSEMBLY

Unscrew the bolt, connect the main cable together (please carefully align the male port and the female port), insert the handlebar into the stem tube, screw in the bolt, and then securely tighten it with two Hex spanners. The required clamping/tightening force is between 5 to 7 N/m.

Note: Please ensure that the hole is not blocked by the cable when you screw in the bolt.

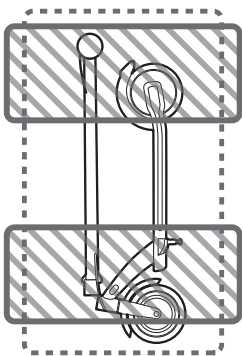
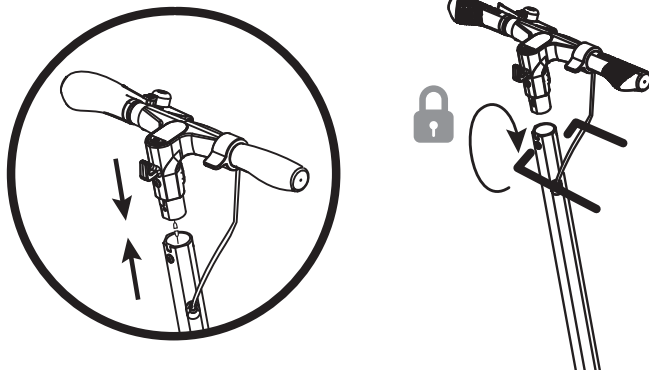

WARNING! RISK OF INJURY BY PINCHING!
DO NOT INSERT YOUR FINGERS INTO THE SHADED AREA INDICATED.

The folding mechanism may loosen after some time of use. In this case, use the supplied hex wrench to tighten the bolt gradually.

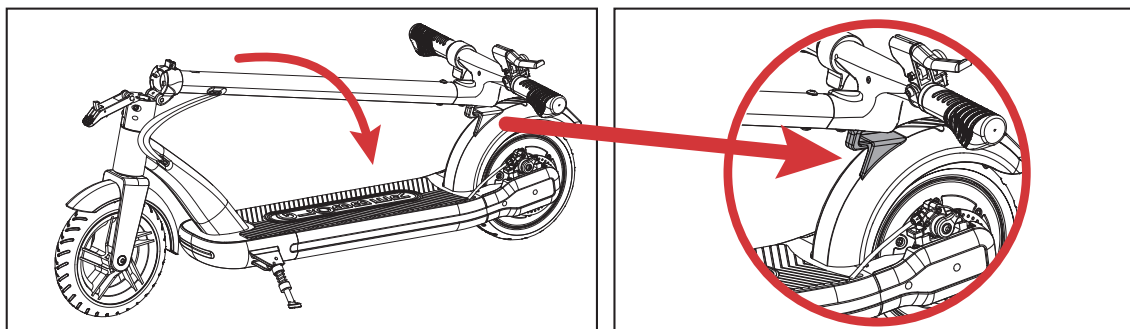

FOLD THE SCOOTER

1. Press the red button located on the folding lever, and open the folding lever.
2. Lower the t-bar until the hooked handlebar is clipped into the rear wheel fender.

Caution: Before lifting the scooter, ensure the hook of the t-bar is securely placed into the rear wheel fender.

5 - CHARGING

When the battery indicator light on the LCD becomes low, you can recharge the battery with the provided charger.

IMPORTANT:

The battery has the feature of temperature protection.

If you try to charge the scooter just after riding, the battery pack might be at a high temperature, and it will not accept charging until about 25 minutes later when the battery pack cools down.

Warning for battery charging: Use only the charging device provided with your scooter.  (model ref. CP4215)

Your electric scooter is delivered with a specific charger; do not use any other charger with the scooter. Only charge the scooter indoors. The external flexible cable of this charger cannot be replaced; in case of damage, the charger must be disposed for recycling.

1. To charge your electric scooter, make sure it is turned off by switching OFF; then remove the waterproof cap from the port and plug in the charger. For safety reasons, ensure the charging port is always dry before starting to charge.
2. Plug the charger into a suitable power source.
3. When the LED light on the charger is red, the battery is charging.
4. When the signal light changes to green, the battery is fully charged; this will take approximately 5-6 hours. You must stop charging it when the signal light turns green; charging the battery for too long will reduce its lifetime.

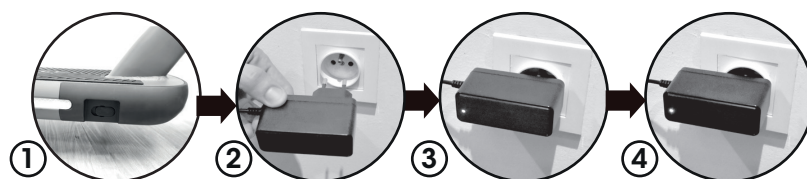

The protective cover is used to protect the charging port from splashing water. Be sure to replace the cap after each charging and before each use.

- Children should not play with the battery appliance.

- Cleaning and user maintenance should not be done by children without adult supervision.

- Warning: The charger (model ref. CP4215) is specific for lithium battery pack 36V and 7.8AH ( model no: 10S3PSCOOTERM26)

- The battery charger has an LED indicator: The GREEN light indicates the battery is fully charged or disconnected; the RED light indicates the battery is charging.

- Do not recharge non-rechargeable batteries. It may cause an explosion.
- Only use the charger supplied with your electric scooter. Using a charger other than the one supplied will invalidate the warranty.
- To optimise the performance and lifetime of your electric scooter battery, fully charge the battery before using it for the first time and fully charge it once a month.
- Do not cover the battery compartment or the charger. There must be good ventilation conditions at all times during charging.
- The charging environment must be clean. Ensure there are no traces of dampness or water in the electric socket before plugging in.
- Ensure you use a standard socket.
- Do not switch on the scooter during charging.

Warning. Do not use the battery or the device in the following cases:

1. The battery gives off a smell or the temperature inside the appliance is extremely high.
2. Battery leaks on the deck of the scooter.

If in doubt please contact us at contact@globber.com

Important:

- Prior to attempting any product repairs yourself, please contact your retailer and/or Globber directly at contact@globber.com to get the full technical and safety recommendations.
- In case of battery leakage, do not touch it.
- Keep children away from the battery if it is leaking or displays any other problems.
- Batteries contain dangerous substances. Do not attempt to open the battery or to insert any solid or liquid substance into the battery or into the body of the appliance.
- Using the battery is subject to authorisation by local authorities.

6 - TIPS FOR USE / CAUTION

Before and after using your appliance, check all the connections: The brake and the wheel axles must be correctly adjusted and undamaged. Also check the wheel wear. Check the steering system and make sure that the nuts are tightened and the handlebars and front wheel are perpendicular. Also eliminate any sharp edges caused by use.

1. If the scooter battery is low or uncharged, the appliance can be used as a standard scooter. To do so, stand on the scooter with your hands on each handlebar and push with one foot to make it move forward. Proceed with caution to start with.
2. A mechanical hand brake is located at the left of the handlebar. When necessary, press it to slow down. Press gradually to avoid skidding or loss of stability.

How to adjust the disk brake on the hand brake:

1. Fine tune the brake block by turning the barrel screw. To do so:
2. First undo the barrel-adjuster's locknut (turn counter-clockwise).
3. To increase the brake power, unscrew the barrel in counter-clockwise direction in small increments. To decrease the brake power, turn the barrel inward in clockwise direction in small increments.
4. Check the feeling of the brake from time to time to finetune the adjustment.
5. Tighten the barrel-adjuster's locknut when done (turn clockwise).

Warning: The rear fender is not a brake; do not use for braking!



- Warning. Any load attached to the handlebars will affect the stability of the vehicle.
- When you use your electric scooter, ensure your position is always correct and respect the local laws and highway codes.
- Always speed up and slow down gradually.
- The scooter is for teenagers and adults. It is not a toy. It is a means of transport and not designed for extreme sports, such as jumps, ramps, ollies, etc. Under no circumstances should the product be used in a skatepark for "aggressive" use (figures, etc.).

- Use with caution on clean, dry flat surfaces and if possible, away from other users. Respect the road safety regulations.
- Braking distances are increased in rainy weather or when wheels are wet.
- Traffic in the city has many obstacles to cross, such as curbs and steps. It is recommended to avoid obstacle jumps. It is important to anticipate and adapt your trajectory and speed to those of a pedestrian before crossing these obstacles. It is also recommended to get off of the vehicle when these obstacles become dangerous due to their shape, height, or slippage.
- Take the time to learn the basics of e-scooting practice to avoid any serious accident that can take place in the first months. Talk to your seller for more information on an appropriate training organization.
- Do not deviate from the intended use of the e-scooter.
- WARNING! Keep plastic covering away from children to avoid suffocation.
- The average A-weighted emission sound pressure level does not exceed 70 dB(A).
- Check local laws concerning the use of scooters. Respect all the traffic rules and road signs. Keep away from pedestrians and users on public highways.
- Preferably use on flat, clean surfaces free from gravel and grease. Avoid bumps and drain gratings likely to cause an accident.
- Avoid high traffic areas and overcrowded areas.
- Walk the scooter across pedestrian crossings.
- Anticipate your trajectory and your speed while respecting the code of the road, the code of the sidewalk, and the most vulnerable.
- In all cases, take care of yourself and others.
- Notify your presence when approaching a pedestrian or cyclist when you are not seen or heard.
- Always wear shoes, and we strongly advise you to wear trousers and long-sleeved shirts to avoid injury if you fall.
- Warning: Wear personal protection equipment, including gloves, knee and elbow protectors, and a helmet. 
- Do not use in the dark if the front light is turned off or not bright enough.
- The electric scooter is not designed for acrobatics. Do not attempt to jump or execute dangerous manoeuvres.
- Do not ride more than one person on the scooter.
- You are advised not to leave the electric scooter outside in damp or wet conditions.
- Do not touch the hub motor and brake disc located in the rear wheel when in use or immediately after riding.
- Check that the kickstand is fully folded before starting. When parking, check that the kickstand is properly unfolded; the unit must be parked on a flat ground to avoid any risk of falling. If the unit is not equipped with a kickstand, ground parking is recommended, ensuring you do not interfere with the traffic.
- It is highly recommended to wear reflective clothing and accessories to enhance/increase your visibility.
- When the product is no longer in use, it should be stored in a safe place or put under protection (lock system) to prevent unauthorized use of the commands/product.
- Vibration and shock: Using an electric scooter can generate significant vibrations and shocks, depending on the surface on which it is used. Do not use your scooter for too long, and immediately stop using if discomfort is caused by vibrations. The total hand-arm vibration value does not exceed 2.5m/s².
- In case of fall or accident, always check that product is switched off and clear the way for other users if possible.
- The front air-filled tire will absorb vibrations.
- The materials used for the construction of the e-scooter are non-toxic and have been analysed according to the following directive: 2011/65/EU Rohs. A safety data sheet has also been established for the battery.
- The safety and reliability of the control systems have been evaluated according to the following guidelines: 2014/30/EU Electromagnetic Compatibility Directive and 2014/35/EU Low Voltage Directive.
- In France, this product is equipped to circulate on certain public roads by users of at least 14 years old. Consult the website: service.public.fr/particuliers/vosdroits/F308.
- In France, it is the responsibility of the users of a motorized mobility device (EDP) to insure. Motorized EDPs may be included in home multi-risk insurance contracts but with a specific civil liability clause of the land motor vehicles (VTM) type, or be the subject of a specific EDP motorized contract.
- To avoid pinching and entrapment, do not put your fingers on get them stuck inside moving parts.

7 – MAINTENANCE

- **Warning:** As with any mechanical component, your vehicle is subject to high stresses and wear. The various materials and components may react differently to wear or fatigue. If the expected service life for a component has been exceeded, it may break suddenly, thereby risking injuries to the user. Cracks, scratches, and discoloration in the areas subject to high stresses indicate that the component has exceeded its service life and should be replaced.
- **Caution:** The rear wheel has a motorised part. If you wish to check the motorized part or change it, contact a qualified technician or a Globber representative at contact@globber.com.
- Eliminate any sharp edges generated by use.
- Do not modify or transform the vehicle, including the steering tube and sleeve, stem, folding mechanism, and rear brake, or the warranty will be invalid.
- Accessories and any additional items which are not approved by the manufacturer shall not be used.
- To clean: Disconnect the charger and turn off the product; then wipe it with a dry cloth.
- The lithium battery: To guarantee the battery lifetime, charge it when its level is low. If it is not used for a long period of time, you are advised to charge it once a month. If you wish to check the battery or change it, contact a qualified technician or a Globber representative at contact@globber.com.
- The recommended storage temperature for the battery is between 5°C and 30°C.
- Do not use or place the electric scooter in an environment where the temperature exceeds 40°C to avoid any lithium battery malfunction that may lead to it catching fire.
- Never store the electric scooter in a car during hot weather to avoid any danger of lithium battery malfunction leading to fire.
- **Bearings:** Avoid riding through water, oil, or sand, which would damage your bearings. To maintain your bearings, check regularly that the front wheel turns properly by turning the electric scooter upside down and pushing the wheel with your fingers. If the front wheel does not turn, remove it and check the condition of the bearings. First unscrew the wheel axle. Remove the axle and remove the wheel. Carefully push the two bearings out of their seating. If they are chipped or crushed, buy new ones. If there is no visible damage, oil them. To do so, remove any traces of grease, mud, or dust from the bearing using a paper towel or a cloth then grease them either with a self-lubricating spray or by soaking them in oil overnight (turn the bearings several times in the oil before leaving them to soak). Refit the bearings and axle and then the front wheel.
- **The rear wheel:** The wheel will wear out over a certain length of time or may even develop holes if the scooter is used on rough surfaces too often. Check the rear wheel regularly and change it when necessary for better safety.
- **The front wheel:** Inflate the air tire to the correct PSI (pressure) as specified on the side of the front tire and check once per week.
- A correct tire pressure is critical to the performance of the front tire.
- Tire specifications are molded into the tire wall (50 PSI/ 340 kpa).
- **How to inflate the tire:**
 - Remove the cap from the tire valve on the tire.
 - Put the pump on the valve and lock with the lever near the nozzle.
 - Keep checking the pressure until you get it right.
 - Put the cap back onto the tire valve.

Warning! Treat the tire with care. Never inflate the tire beyond the maximum permissible pressure, otherwise it might burst or come off the rim during the ride. Risk of an accident!

- **Product modifications:** The original product must by no means be modified except for the maintenance-related changes mentioned in these instructions.
- **Nuts, axles, and other self-locking fasteners:** These should also be checked regularly. They can become loose after a while in which case they should be tightened. They can become worn and not tighten properly, in which case they should be replaced.

8 - DISPOSAL OF END-OF-LIFE APPLIANCE

The appliance must be disconnected from the main power supply when removing the battery.

The battery must be removed from the appliance before the appliance is discarded.

The battery must be disposed of safely by taking it to the most suitable collection point.

Do not place with regular waste; dispose in recycling bin.

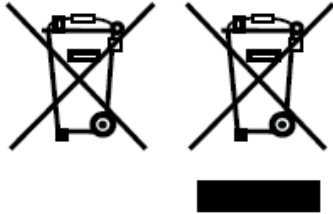

9 - ADDITIONAL INFO

For questions and inquiries please contact us at contact@globber.com

WARRANTY

The manufacturer warrants this product to be free of manufacturing defects for a period of 2 years from the date of purchase. This Limited Warranty does not cover normal wear and tear, tire, tube, or cables, or any damage, failure, or loss caused by improper assembly, maintenance, or storage.

This Limited Warranty will be void if the product is ever:

- Used in a manner other than for recreation or transportation;
- Modified in any way;
- Rented

The manufacturer is not liable for incidental or consequential loss or damage due directly or indirectly to the use of this product.

Globber does not offer an extended warranty. If you have purchased an extended warranty, it must be honoured by the store at which it was purchased.

For your records, save your original sales receipt with this manual and write the product name below.

.....

E-scooter batteries are covered by a 1-year warranty from the date of purchase.

SPARE PARTS

To order spare parts for this product, please visit our website globber.com

10 – TROUBLESHOOTING

Problem	Possible cause	Solution
Scooter will not run	Battery is not charged - LCD screen is OFF	Fully charge the battery. The first charge takes approximately 5-6 hours and up to 6 hours for recharges.
	Wires or connectors are loose or unplugged	Check to ensure that the charger is securely plugged on both the wall socket and the scooter.
Scooter run time is short	The battery does not charge completely. The LCD screen shows a low battery level	Fully charge the battery. The first charge takes approximately 5-6 hours and up to 6 hours for recharges. Check to ensure that the charger is securely plugged into both the wall socket and the scooter. Make sure that the wall socket is connected to the main power.
	Battery will not charge fully	1 - You have been using your scooter for a while. The battery has lost its capacity. The average rechargeable battery life is 1 to 2 years depending on scooter conditions and use, maintenance (at least one charging per month), and storage (dry place at a temperature between 5 and 30 degrees Celsius). 2 - Your scooter is new and has low autonomy? In both cases (1 and 2), the battery needs to be changed, please contact your dealer or a Globber representative at contact@globber.com
Scooter suddenly stops working	Excessive use of scooters	Excessive overload occurs during a steep incline or when the rider is too heavy; the motor has over-load protection to ensure safety. If such a sudden stop of the scooter occurs, wait about a minute or more before switching the battery on again.
	Wires or connectors are loose or unplugged	Check all wires and connectors to make sure they are connected and secure.
	Improper use in wet environment which has led to an electronic short cut	Your scooter is not designed for wet, rain, or puddle use. If your problem arises as a result of such use, please contact your dealer or a Globber representative at contact@globber.com
Scooter runs sluggishly	Scooter is overloaded	Be careful not to overload the scooter beyond the maximum weight limit (100 kg). Be careful not to use your scooter on steep slopes, and do not pull or tow objects or people. Avoid overloading the scooter as this will cause premature wear of the battery and its components.
	Unsuitable riding conditions	Ride only on solid, flat, clean and dry surfaces, such as a bike path or level ground.

11 – BUILT-IN MALFUNCTION DETECTION SYSTEM

This E-MOTION 27 scooter has a built-in malfunction detection system. In the event of an electrical problem, the screen will display an ERROR code. Refer to the below table to find the related cause and remedial actions required.

IMPORTANT: Prior to repairing, contact your retailer to get disassembly and assembly recommendations at contact@globber.com.

To order spare parts for this product, please visit our website at globber.com or contact us at contact@globber.com.

ERROR CODE	CAUSE	ACTIONS
E1	Brake error	1) Check whether the dial wire is plugged correctly. 2) If the E1 error is reported again, it is a brake dial fault. - Replace brake dial to test. Then if no error is reported again the problem is resolved.
E2/F2	Accelerator error	1) Check whether the dial wire is plugged correctly. 2) If the E2/F2 error is reported again, it is an accelerator dial fault. - Replace accelerator dial to test. Then if no error is reported again, the problem is resolved.
E3	LCD communication error	1) Check whether the main cable is plugged correctly. 2) If the main cable is plugged correctly, but the E3 error is reported again, replace the main cable. 3) If the E3 error is still reported after the main cable replacement, replace the controller. 4) If the E3 error is still reported after the controller is replaced, please replace the LCD. Then if no error is reported again, the problem is resolved.
E4	Over current protection	If the E4 error is reported continuously, it is considered to be a hardware fault of controller. Replace the controller. Then if no error is reported again, the problem is resolved.
E7	Motor error	1) Check whether the hall wiring is loose (motor cable). 2) If the wiring is good, but the E7 error is still reported, the motor hall is damaged and needs to be replaced. Replace the motor. Then if no error is reported again, the problem is resolved.
E9	Hardware error	Controller's fault: 1) Restart several times. 2) If the E9 error is reported again. Replace the controller. Then if no error is reported again, the problem is resolved.

